

ACQUAPURO



APPLICATIONS

Kitchen Filtration Taps / ICE Makers / Drinking Fountains / Vending Machines

FEATURES

- Scale(rust) and Clogging prevention
- Taste and Odor reduction
- Cyst reduction such as Cryptosporidium by mechanical means.
- Particulate reduction such as 0.5~1micron of Dust by mechanical means.
- Certified Bacteriostatic effects by NSF

‘Microfilter’ Water Filtration Product Model ACQ-0.IFC - single System helps to improve the taste, appearance and consistency of your Drinking water beverages at flow rates up to 1.5 ~ 2.5 gpm.

The ACQ-0.IFC (FX) System combines cyst, turbidity and ¹⁾bacterial reduction with particulate class1, chlorine, taste and odor reduction for up to 7,925 ~ 26,000 gallons.

PRODUCT SPECIFICATION

System Model Name	Capacity	Flow rate	Reduction Claims	²⁾ Nominal Micron Rating
ACQ-0.IFC	7,925 gallons (30,000 liters)	1.5 gpm (5.68 lpm)	Chlorine Taste and Odor, Bacteriostatic, Particulate Class1, Turbidity, Cyst, ¹⁾ Bacteria	0.1

¹⁾ As tested with E.Coli, Staphylococcus aureus, Pseudomonas aeruginosa by manufacturer’s

²⁾ As tested and verified by manufacturer’s



PRODUCT BENEFITS

- **Consistent high-quality, great tasting water for continued customer satisfaction.**
- **Hybrid cartridge suitable for tight space.**
 - : Four(4) step technology "All-In-one" cartridge construction combines a Micro-membrane (UF) in series with premium carbon block and Sediment filtration to provide superior throughput, performance and cartridge life.
- **Efficient removal by 0.1micron UF filter**
 - : Reduction of up to 99.99% of common water-borne bacteria by micro-membrane(UF) filtration as tested by manufacturer's laboratory.
- **FX System which effectively filters dirt and particles as small as under the 0.1 micron in size by mechanical means.**
 - : Reduction of particulate and abrasive hard particles help prevent equipment wear and helps extend the life of pumps, valves, o-rings and seals.
- **Inhibits any potential bacterial growth.**
 - : The term 'bacteriostatic' indicates that the system limits the passage or growth of bacteria that may already exist in the incoming water.
- **FX-Basic filter cartridges contain Micro-membrane filtration(UF) which eliminates bacteria thus providing clean edible water for end-users.**
 - : FX Filter System for superior dust-holding capability was NSF/ANSI 53 certified to reduce cysts such as Cryptosporidium and Giardia by mechanical means. Bacteria in drinking water are one of the most harmful contaminants that one can encounter. It causes numerous infectious diseases such as dysentery, cholera, hepatitis and typhoid etc. Bacteria can be transferred to edible water in various ways such as from human and animal waste. Bacteria enters water through diverse precipitation canals such as snow melt and rainfalls.
- **Sanitary cartridge replacement is simple, quick and clean with a 1/4 turn.**
 - : Cartridges are sanitary in design, requiring no contact with the filter media during cartridge change-out.
- **3/8" One-tuch fitting horizontal inlet and outlet ports allow direct or easily adaptable connections to existing plumbing lines.**
- **Compatible filter key structure.**
- **Robust & Aesthetic appreciated Design.**
 - : Thicker cartridge (t: 5.6mm vs avg. 5.0mm), FDA certified materials
 - : "Easy-Grip" (Ø : 75mm vs avg. 78mm)



NSF CERTIFICATION



- EPA Est No. 94813-KOR-1
- System Trade Name: ACQ-0.IFC (FX)

System Tested and Certified by NSF International against NSF/ANSI 42 & 53 for the reduction of chlorine, Taste and Odor, Nominal Particulate Class1, Turbidity, Cyst and Bacteriostatic effects.

The system(s) conform(s) to NSF/ANSI 42 and 53 for the specific performance claims as verified and substantiated by test data.

This system has been tested according to NSF/ANSI 42&53 for reduction of the substances listed below. The concentration of the indicated substances in water entering the system was reduced to a concentration less than or equal to the permissible limit for water leaving the system, as specified in NSF/ANSI 42&53.

NSF Performance Data Sheet (PDS) is included. (Page. 4)

OPERATION

System Model Name	Working Pressure	Water Temperature	Inlet / Outlet Size
ACQ-0.IFC	10 ~ 125 psi	4 ~ 38 °C	3/8 inch

- The system includes a head assembly with integrated mounting bracket and a single cartridge filter.
- Inlet and outlet plumbing connection are 3/8" one-touch fitting.
- Filter cartridges are O-ring seal type.
- System maximum operating pressure of 125 psi (862 kPa) and operating temperature of 100°F (37.8°C).

FILTRATION PROCESS

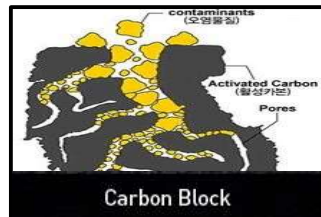
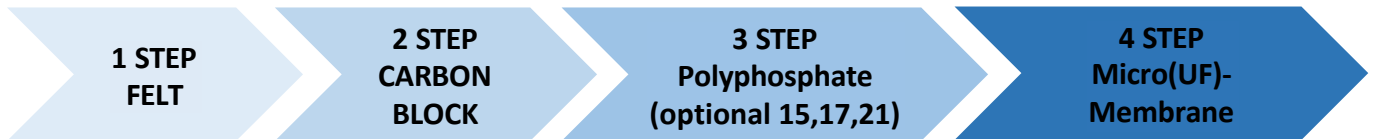

ACQUAPURO

PRODUCT DRAWING

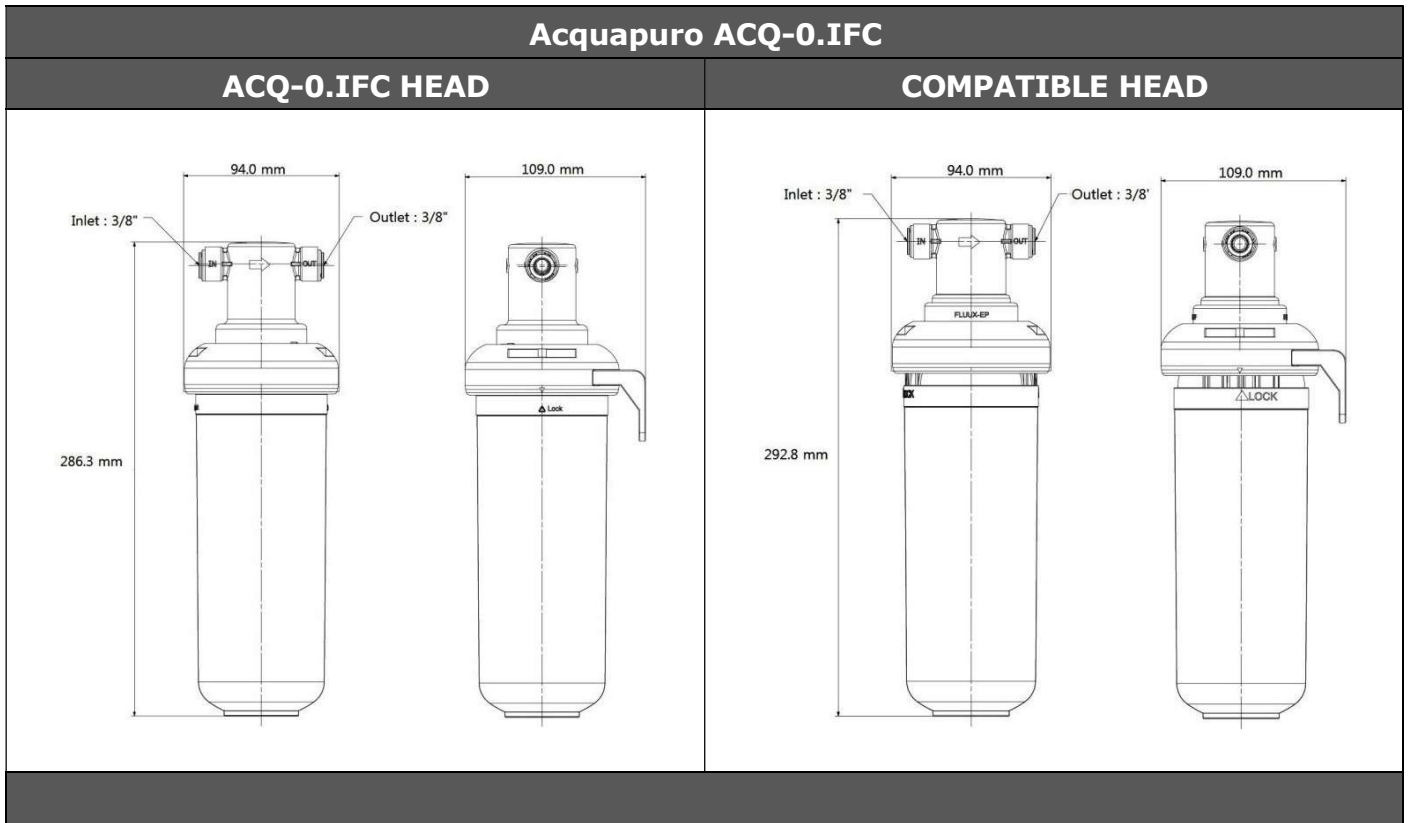

The left product is the ACQ-0.IFC filter and head, the right product is a compatible head with the Acquapuro ACQ-0.IFC filter.

PERFORMANCE DATA SHEET (NSF Certification)

ACQ-0.IFC (FX)	Influent Challenge Concentration	Average Reduction	Reduction requirement	Max Permissible Product Water Concentration
Chlorine Taste and Odor	2.0mg/L±10%	97.3%	≥ 50%	N/A
Nominal Particulate Class1 >0.5µm to <1µm	At least 10,000 particles/mL	>99.9%	≥ 85%	N/A
Cyst	Min 50,000 cysts/L	>99.99%	≥ 99.95%	N/A
Turbidity	11±1NTU	>99.1%	N/A	0.5 NTU
¹⁾ Bacteriostatic	10 ¹ and 10 ⁶ organisms (colony forming units, CFU/mL)	Pass	N/A	0.1 mg/L

¹⁾ The term 'bacteriostatic' indicates that the system limits the passage or growth of bacteria that may already exist in the incoming water. Bacteriostatic filters do not kill bacteria, per say, but do inhibit the growth of bacteria within the filter*. In other words, the term Bacteriostatic means that the quantity of bacteria passing through the filtration system will remain static, i.e. bacteria will not multiply.

INSTALLATION INSTRUCTIONS

How to replace the filter

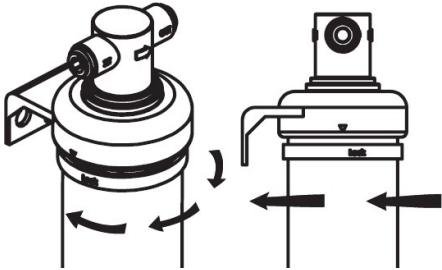

1. Shut off water and relieve line pressure.
2. Hold head firmly. Rotate the old cartridge counter clockwise 1/4 turn and pull it out.

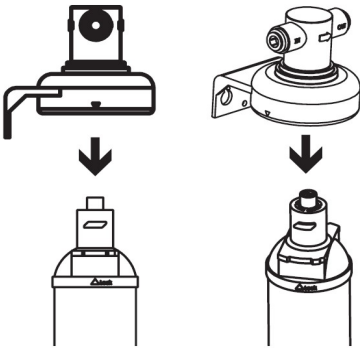

3. Pull cartridge down and out of head.

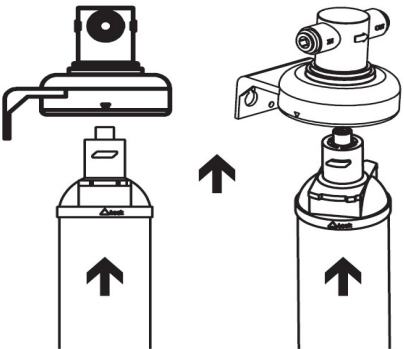

4. Hold head firmly. Insert new cartridge into the filter head.

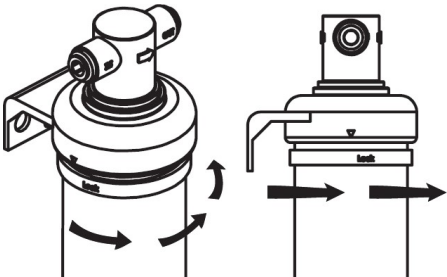

5. Turn the new cartridge into the filter and rotate clockwise 1/4 until rotation clicks and stops. Make sure that the filter cartridge arrow on the top collar aligns with the arrow on the head.
6. Flush filter for 5 minutes before use or until water runs clear.
7. System is ready to use.



WARNING

These installation tips are for informational purposes only and are not intended to be used as actual installation instructions. CAUTION: To reduce the risk associated with property damage due to water leakage:

- Read and follow Use Instructions before installation and use of this system.
System must be installed and operated in accordance with manufacturer's recommended procedures and guidelines. Failure to do so may void warranty.
- Installation and use MUST comply with all state and local plumbing codes.
- Protect from freezing, remove filter cartridge when temperatures are expected to drop below 39.2°F (4.0°C).
- Do not install on hot water supply lines. The maximum operating water temperature of this filter system is 100°F (37.8°C).
; For Cold water Only.
- Do not install if water pressure exceeds 125 psi (862 kPa). If your water pressure exceeds 60 psi (414 kPa), you must install a pressure limiting valve. Contact a plumbing professional if you are uncertain how to check your water pressure.
- Do not install where water hammer conditions may occur. If water hammer conditions exist you must install a water hammer arrester. Contact a plumbing professional if you are uncertain how to check for this condition.
- The disposable filter cartridge MUST be replaced every 12 months, before rated capacity is reached or sooner if a noticeable reduction in flow rate occurs.
- Failure to replace the disposable filter cartridge at recommended intervals may lead to reduced filter performance and failure of the filter, causing property damage from water leakage or flooding.
- To order a replacement cartridge visit www.acquapuro.co.uk.
- Adsorption media will not be regenerated and used.

WARNING: To reduce the risk associated with the ingestion of contaminants:

- Do not use with water that is microbiologically unsafe or of unknown quality without adequate disinfection before or after the system. Systems certified for cyst reduction may be used on disinfected water that may contain filterable cysts.
- Product performance may vary according to flow rate influent line pressure and local water conditions.

MICROFILTER Co. Ltd recommends regularly scheduled maintenance and replacement of the filter cartridge(s) in order for the product to perform as advertised/sold. MICROFILTER Co. Ltd shall not be liable for system failures due to improper maintenance.

Improper installation and maintenance may result in property damage due to water leakage.

Limited Warranty

- Water treatment systems by MICROFILTER (excluding replaceable elements) are covered by a limited warranty against defects in workmanship for a period of two (2) years after date of purchase.
- FOR one (1) YEAR from the date of sale this appliance is warranted against defects in material workmanship but, No warranty is given as to the service life of any filter cartridge or membrane as it will vary with local water conditions and water consumption.
- Replaceable elements (filter cartridges and water treatment cartridges) are covered by a limited warranty against defects in material and workmanship for a period of one (1) year after date of purchase.
- This warranty does not cover failures resulting from abuse, misuse, alteration or damage not caused by MICROFILTER or failure to follow installation and use instructions.
- MICROFILTER will not be liable for any indirect, special, incidental, or consequential damages arising from the use of this Product. Some states and countries do not allow the exclusion or limitation of incidental or consequential damages, so the above limitation or exclusion may not apply to you.
- Do not use non-genuine filters in the FLUUX system.
If you use a non-genuine filter, we will not be responsible for any damages, including damage from leaks.
- Proof of purchase (original sales receipt) must accompany the warranty claim, along with a complete description of the Product, model number and alleged defect.

'MICROFILTER Co.,Ltd.' MAKES NO OTHER WARRANTIES OR CONDITIONS, EXPRESS OR IMPLIED, INCLUDING, BUT NOT LIMITED TO, ANY IMPLIED WARRANTY OR CONDITION OF MERCHANTABILITY OR FITNESS FOR A PARTICULAR PURPOSE OR ANY IMPLIED WARRANTY OR CONDITION ARISING OUT OF A COURSE OF DEALING, CUSTOMER OR USAGE OF TRADE.



Stabilization

Tested by Microfilter

ACQ-0.IFC	Influent	0~30 sec	5 min	15 min
Turbidity (NTU)	0.104	0.064	0.064	0.059
TDS (ppm)	149.8	194.6	150.8	150.7
pH	7.85	8.39	8.29	8.17

Flow rate & Pressure drop Test Result

Tested by Microfilter. co.,

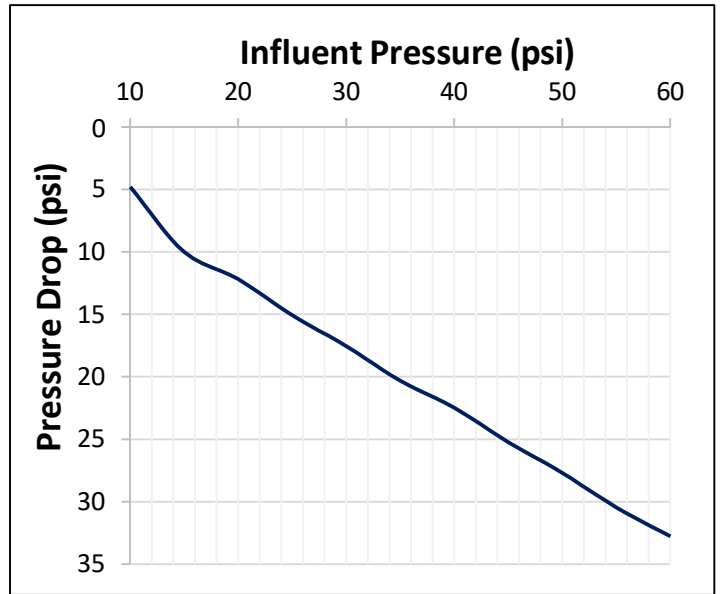
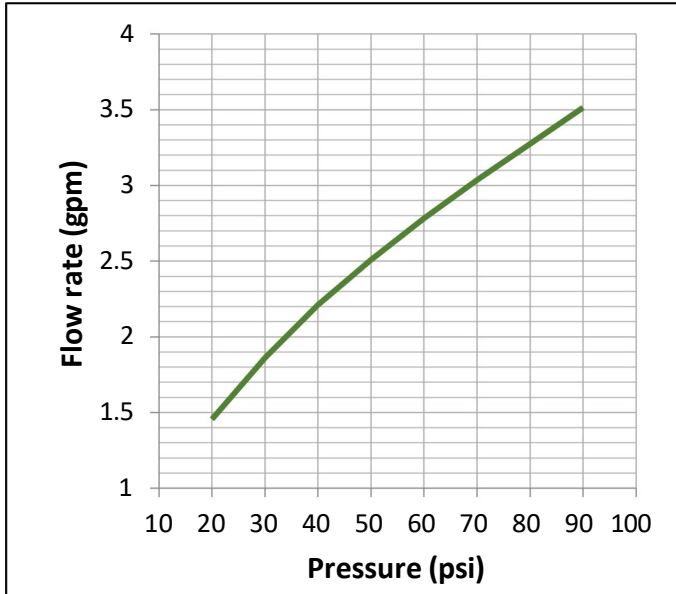

Clogging Test Result

Tested by Microfilter. co.,

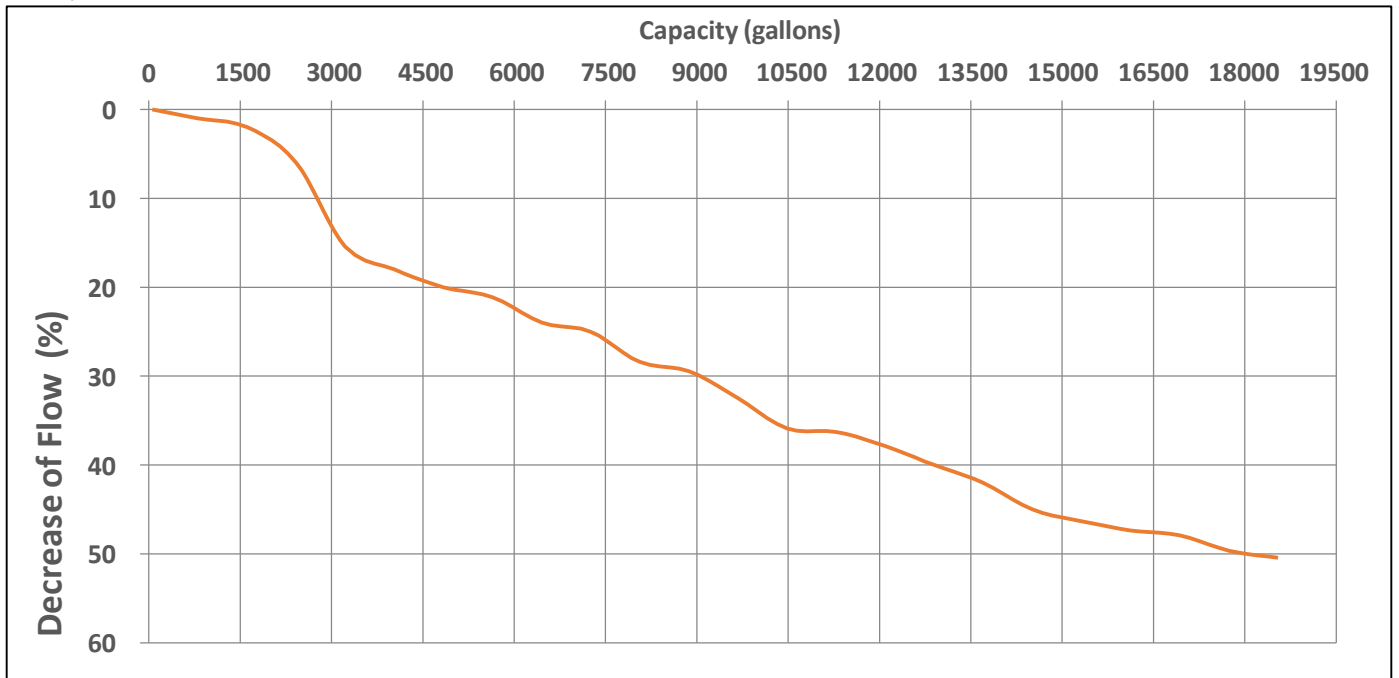

This is a test for the Acquapuro ACQ-0.IFC filter, results may vary according to flow rate influent line pressure and local water conditions. For detailed filter performance, please refer to the page.6 data sheet.

